

6.

Assembly - Parts: I
Final frame assembly.
 Check all assembly points, **Fully tighten all nuts** before
 Securely fitting the foot covers to all 4 corners of the
 frame.

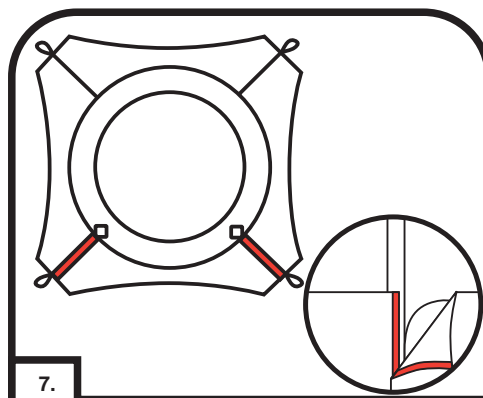

7.

Assembly - Parts: F
Cover Assembly.
 With the cover now attached to the trampoline, close
 the 2 front attachment sections of the cover

**PLEASE NOTE: ENSURE YOU HAVE CHECKED ALL
 OF THE ASSEMBLY POINTS BEFORE EACH USE.**

**PLEASE NOTE: TO CORRECT ANY WOBBLE,
 TILT THE FRAME ONTO ITS BACK, HOLDING
 THE HANDLES ABOVE THE LEGS, SHIFT THE
 ALIGNMENT SLIGHTLY TO THE LEFT OR RIGHT.**

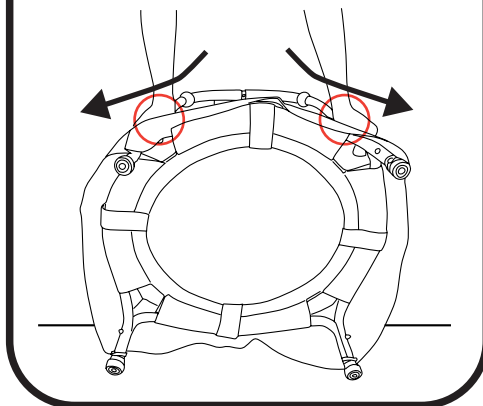

RETAIN THIS INFORMATION FOR FUTURE REFERENCE.

My First trampoline

Encourages development through physical activity

12M +

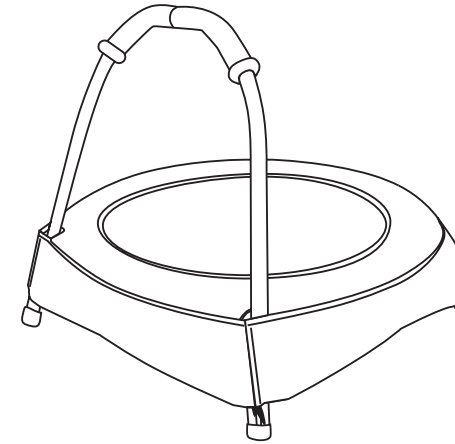

WARNING!

- **CONSTANT PARENTAL SUPERVISION,
DO NOT LEAVE CHILDREN UNATTENDED WITH THIS PRODUCT.**
- **WHEN USING OUTDOORS, ONLY USE IN DRY CONDITIONS.**
- **DO NOT LEAVE PRODUCT OUTDOORS.**
- **STORE INDOORS WHEN NOT IN USE.**

Before assembly

- This toy must be assembled by an adult. **Ensure bolts and small components are kept out of reach of young children.**
- Please remove all packaging attachments before giving this product to your child.

Before each use

- Young children in play are unaware of potential dangers and hazards, therefore responsible adult supervision is essential.
- Ensure pets, other children or obstructions are not hiding under the trampoline.
- Ensure your child bounces as near to the centre of the mat as possible.
- Suitable for indoor and outdoor use
- Use in an open flat level area. If outside, use on grassed area at least 2m away from patios, driveways etc. If indoors, use away from furniture and other obstacles.
- Ensure children are not wearing loose clothing that could snag on the equipment, such as baggy pockets, hoods or jewellery.
- Do not allow your child to attempt somersaults or stunts whilst on product.
- Check all fixings regularly, tighten if necessary, and check that the suspension system is secure.
- Check metal sections or components for signs of corrosion.
- Recommended for children from 12m +
- Maximum weight of user - 20kg.
- No more than 1 child at any one time.
- For family domestic use only.
- Failure to comply with these precautions may result in injury.
- Discontinue use if weakening or breakage found. Contact our Customer Services Department in the event of a failure.



Kid Active!® Collection

The Innovation Factory
 St. Columb Major
 Business Park,
 Cornwall
 TR9 6SX
 United Kingdom

CUSTOMER CARE

FREEPHONE: 0800 389 8591 (UK only)
www.worldsapart.com
customercare@worldsapart.com



PLEASE READ ALL INSTRUCTIONS AND WARNINGS BEFORE ASSEMBLY

We advise that you check all the parts against the parts list before starting.
The Trampoline must be assembled by an adult, perhaps with another to help.

PARTS LISTING

A x 1



Frame leg A

B x 1



Frame leg B

C x 2



Frame leg C

D x 1



Handle frame D

E x 1



Handle frame E

F x 1

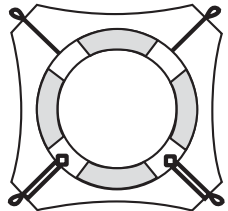

Mat with Cover

G x 8



Bolt set

H x 1



Spanner

I x 4

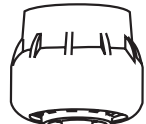

Foot Cover

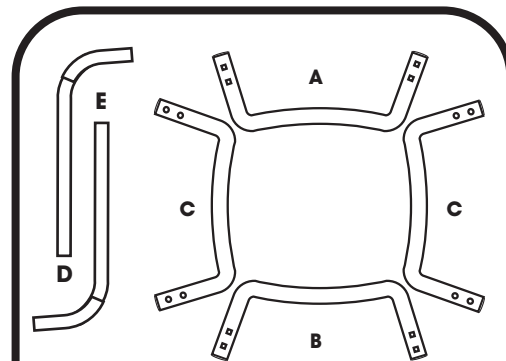

1.

Assembly - Parts: A,B,C,D & E

Select Area.

Lay the frame out on the floor - refer to parts list.
Critical: Check square holes and round holes are positioned as shown

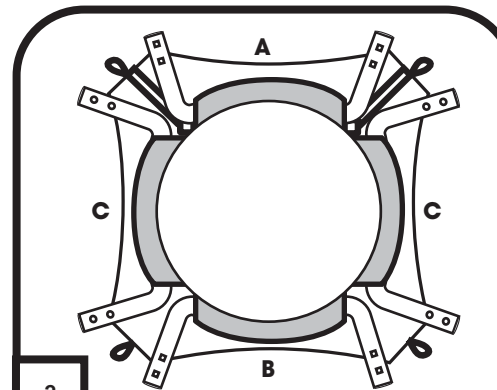

2.

Assembly - Parts: A,B,C & F
Select Area.

Insert frame legs only, into mat as shown - refer to parts list.

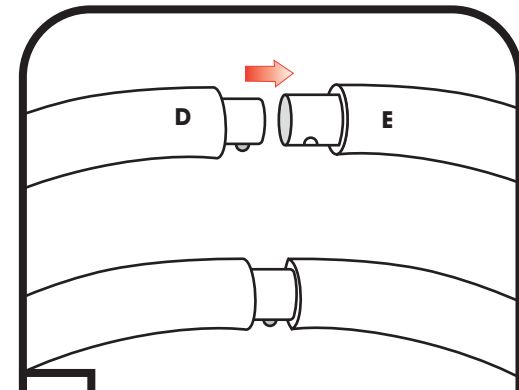

3.

Assembly - Parts: D & E
Assembly.

Assemble handle by fixing the handle legs together to form an arch. Make sure the spring peg fits into the hole. Spring peg to face downwards when assembled.

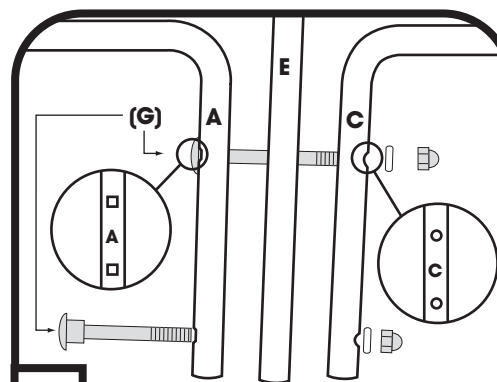

4.

Assembly - Parts: A,C,E & G

Slot handle leg (E) between frame legs (A&C). Insert bolt (G) through frame leg (A), handle leg (E), and then through frame leg (C). Fasten frames together with the washer and dome nut from bolt (G).

Repeat this sequence again on the opposite side using frame legs (A&C), handle leg (A) and bolt (G).

LOOSLEY FASTEN THE NUTS AT THIS STAGE.

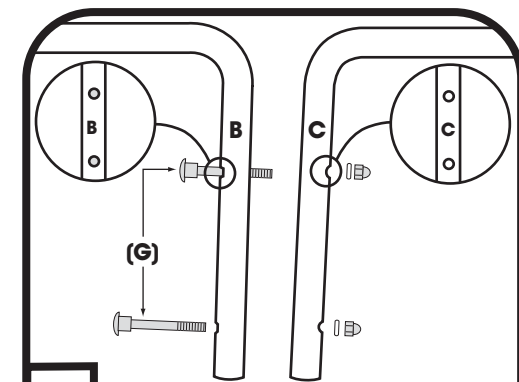

5.

Assembly - Parts: B,C & G

Insert bolt (G) through frame leg (B) and then through frame leg (C). Fasten frames together with the washer and dome nut from bolt (G).

Repeat this sequence again on the opposite side using frame legs (B&C) and bolt (G).